

GLASS OPTIMISATION SOFTWARE WITH THE BEST YIELD



24/7 support line

Software supports
in any language

Compatible with
all cutting tables

 **SPIL**
OPTI

THINKING ABOUT HIGH YIELD

www.spilglass.com

Here is

WHY YOU SHOULD UPGRADE

your current Optimisation software to

SPIL OPTI

SPIL OPTI is the glass optimisation software developed by SPIL Software using complex optimisation algorithms to reduce material usage and improve efficiency of the processing time while giving the best yield.

- SPIL OPTI can seamlessly integrate with SPIL ERP or any Glass Software in the market.
- SPIL shape library with hundreds of simple and complex shapes.
- Different shape templates for shower cubicles, fencing, decorative use etc.
- Custom draw shapes.
- Shape nesting.
- Maintain glass inventory.

SPIL OPTI is developed using the latest technologies and complex algorithms which makes the Glass Optimisation convenient regardless of the cutting machine you have. Simply our optimisation solution can be linked with almost all the cutting tables of any make. This makes SPIL OPTI a sophisticated optimiser for your business which guarantee the best yield.

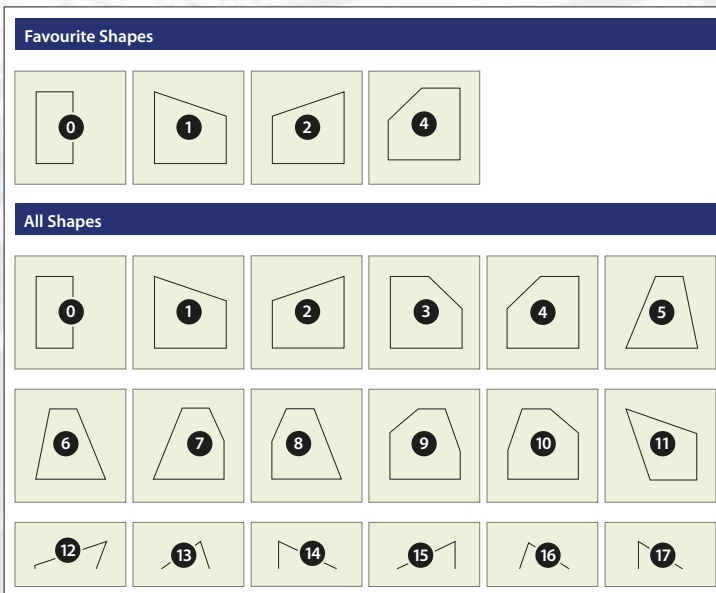

Cut Size	1004.0 x 2004.0
Finish Size	1000.0 x 2000.0
Area	1.9802m2
Circumference	6537.0mm

Measurements	
E1	1000.0
E2	2000.0
E3	1000.0
E4	2000.0

Border/Offset	
TOP	0.0
LEFT	0.0
RIGHT	0.0
BOTTOM	0.0

- Show Edge Details
- Show Edge Services
- Show Dimensions

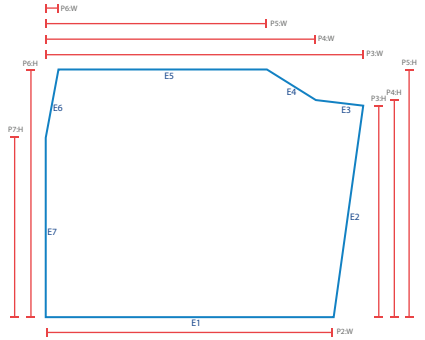
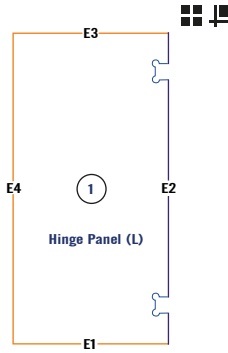

Custom Shape Draw

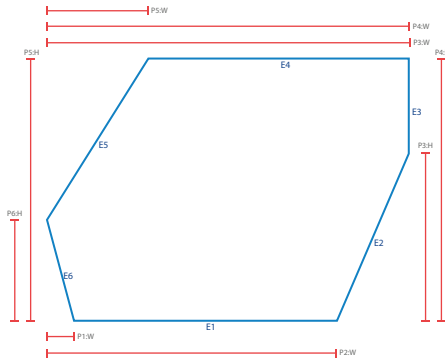

Dimensions

P1	40.0	0.0
P2	430.0	0.0
P3	540.0	250.0
P4	540.0	390.0
P5	150.0	390.0
P6	0.0	150.0

Rotation

-
-
-
-
-

Export

With dimensions

Custom Shape Draw

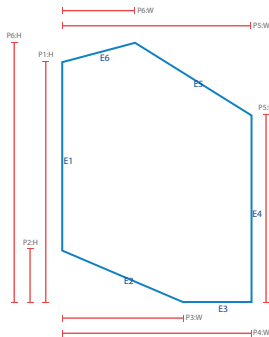

Dimensions

P1	40.0	0.0
P2	430.0	0.0
P3	540.0	250.0
P4	540.0	390.0
P5	150.0	390.0
P6	0.0	150.0

Rotation

-
-
-
-
-

Export

With dimensions

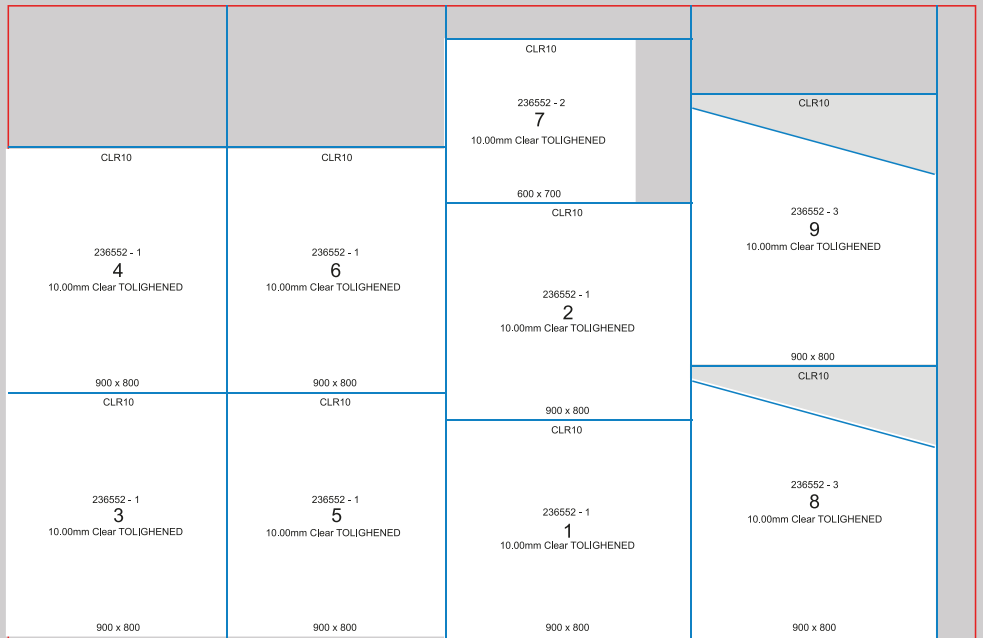
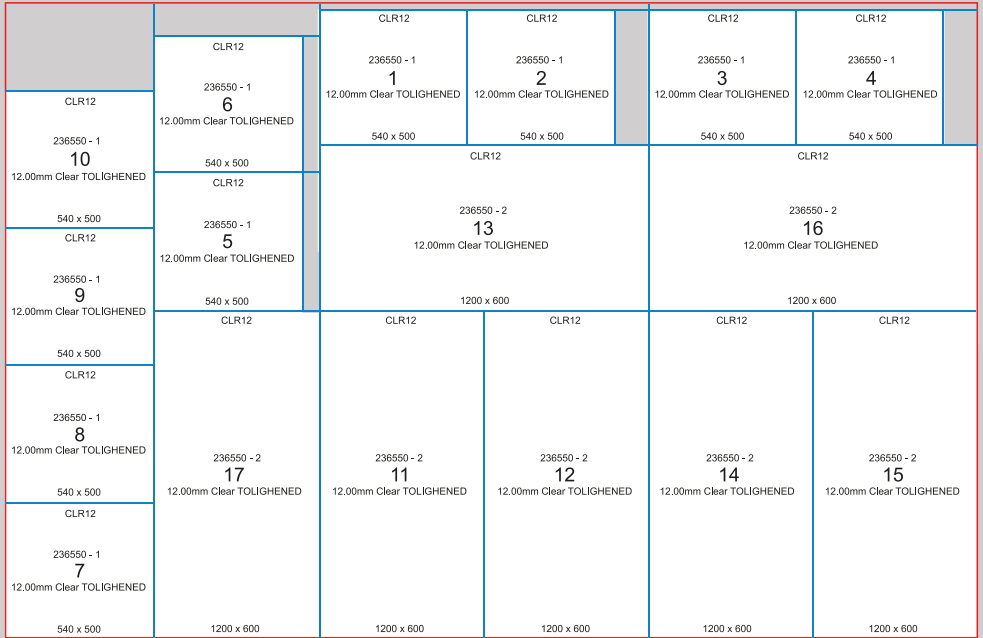

Features and Functionality of SPIL Shape Library/Catalogue

- ▶ Easy to use and intuitive, with a custom and free drawable shape interface.
- ▶ You can design your own shapes, or rotate and flip them clockwise or counter clockwise to align with customer drawings.
- ▶ Import DXF and DWG files directly from customers.
- ▶ SPIL shape library integrates seamlessly with order entry, so you can auto-fetch processes linked to the shape.
- ▶ Eliminates double handling, speeds up entry, and minimises errors.
- ▶ Quickly and easily add polishing to edges, with instant graphical representation.
- ▶ Automated trims and grinding are based on the thickness and type of polishing.
- ▶ The cut out library is extensive and easy to use.
- ▶ Able to find the shapes you need, and export them directly from order entry into WaterJets and CNC machines in DXF or DWG formats.
- ▶ Shape nesting optimizes yield and is ideal for larger quantities.

Features and Functionality of SPIL OPTI Optimisation

- ▶ SPIL OPTI supports all cutting tables on the market.
- ▶ Optimises the cutting process to maximise yield and minimise waste, which can help you increase profits.
- ▶ Centralized glass management, for instance glass types and glass sheet management, making it easy for multiple users to access and track glass.
- ▶ Helps you manage offcuts with designated racks and labels, so you can easily track and reuse them.
- ▶ Optimise with standard shapes, DXF and DWG files, so you can use a variety of input formats.
- ▶ Customisable label formats for different customer groups, so you can create labels that are clear and easy to understand.
- ▶ Label printing in the office or at the cutting table, so you can always have the right labels when you need them.
- ▶ SPIL OPTI includes Opti-TV, which allows you to visualize the cutting process on a TV screen at the cutting table.
- ▶ OPTI TV helps you to visualise accuracy and efficiency of the cutting process.
- ▶ Automatically tag or mark all panels on the sheet being cut, so you can easily identify them.
- ▶ Automatic reduction of sheet stock in sync with the cutting process, so you always have an accurate view of your inventory levels.
- ▶ Seamless integration with SPIL inventory module.
- ▶ Track stock levels and reserve stocks for specific customers or projects.
- ▶ Provides comprehensive reporting, for you to track yield vs waste across different glass types and thicknesses.

“

Our main company is Rottler und Rüdiger und Partner GmbH, a manufacturer of special machinery for IGUs' and MPK – Modelle profile Konfektion GMBH is our subsidiary supplier of final material components for IGU manufacturers and for that we use enhanced features of SPIL Opti to produce those profiles. We have been using SPIL Opti features from 2014 and we are very satisfied with their support and product customisation to fit into our business. We do recommend SPIL Opti for any prospective business to try out.



Christian Auer

Head of IT
Rottler und Rüdiger und Partner GmbH
- Germany

”

**REACH OUT TO US
TO FIND MORE**



Contact us on
+61 390 000 065



Email on
info@spilglass.com

www.spilglass.com